

Synthesis, crystal structure, conductivity and magnetic properties of trifluoromethylated dinuclear copper(II) complexes with tetracyanoquinodimethane

Pascal G. Lacroix* and Jean-Claude Daran

Equipe Simbio, LCC/CNRS, 205 route de Narbonne, 31077 Toulouse Cédex, France

A new compound of formula $[\text{Cu}_2\text{L}^2][\text{tcnq}]_3$ has been obtained where L^2 is the Robson-type binucleating macrocyclic dianionic ligand obtained by condensation of 1,3-diaminopropane and 2,6-diformyl-4-trifluoromethylphenol and tcnq is tetracyanoquinodimethane. A comparison of the spectroscopic, conducting and magnetic properties of this compound with those of related copper–tcnq materials affords a reasonable understanding of the electronic properties. Single crystals of a partially fluorinated compound of formula $[\text{Cu}_2\text{L}^3][\text{tcnq}]_3$ have been obtained. A careful examination of the crystallographic data suggests similar properties for both fluorinated compounds.

Solids containing tetracyanoquinodimethane monoanions (tcnq^-) are among the most extensively studied systems in the field of quasi-one-dimensional materials with electrical and magnetic properties.^{1–5} Molecular metals and semiconductors based on tcnq units exhibit different physical characteristics, depending on the nature of the positive organic or inorganic counter ions. The use of inorganic cationic species is a convenient route to molecular materials where magnetic electrons are located in close proximity to itinerant π carriers, which might bring about tcnq^- salts with unique characteristics, such as magnetisation⁶ or spin-crossover behaviour.⁷ Such materials, which could be used to construct new devices for industrial applications or to test theories that describe the electronic structures of solids, offer both theoretical and practical interest.

Following the initial work of Melby *et al.*,⁸ several counter ions based on copper(II) were studied as tcnq^- salts.^{9–16} Most of their conducting and magnetic properties can be understood from the amount of charge transferred from the tcnq units to the metal centre. According to Wheland's empirical rule,¹⁷ the redox potential of the complexes is a good parameter to assess the magnitude of the charge transfer. On the other hand, the role of tcnq^- in the co-ordination sphere around the copper(II) species, which is not taken into account, must be an important factor, and it would be worthwhile to investigate a set of 'Cu–L–tcnq' salts in which the redox potential of the metal could vary with the nature of the ligand, the co-ordination sphere being roughly unaffected.

Our contribution in this field started a few years ago¹⁸ with the synthesis of $[\text{Cu}^{\text{II}}_2\text{L}^1][\text{tcnq}]_2$, L^1 being a Robson-type binucleating ligand obtained by condensation of 1,3-diaminopropane and 2,6-diformyl-4-methylphenol. We didn't observe any charge transfer from tcnq^- to Cu^{II} in this compound, the metal being poorly reducible. In this second paper we follow the same goal using L^2 , a related macrocycle which makes the metal centre more reducible but doesn't affect the copper co-ordination sphere, with the idea of increasing the interaction between itinerant π carriers and localised electrons. A compound of formula $[\text{Cu}_2\text{L}^2][\text{tcnq}]_3$ has been synthesized with three tcnq units instead of two for the methylated derivative. In addition, the structure of $[\text{Cu}_2\text{L}^3][\text{tcnq}]_3$, a different but closely related compound, has been obtained. We discuss the physical properties of both in comparison with those of other copper dimers containing tcnq salts previously described, $[\text{Cu}_2\text{L}^1][\text{tcnq}]_2$ and $[\text{Cu}_2(\text{bipy})_2(\text{OH})_2][\text{tcnq}]_2$ (bipy = 2,2'-bipyridine).

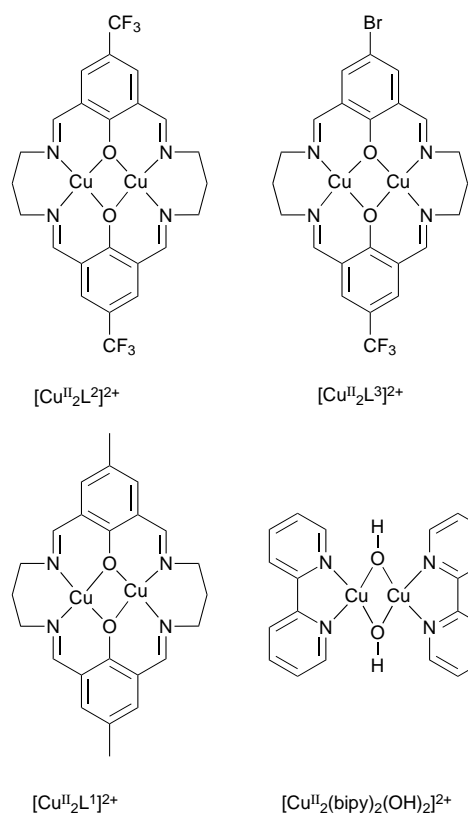

Experimental

Starting materials

Tetracyanoquinodimethane and tetrabutylammonium tetrafluoroborate were obtained from Janssen Chimica, $\text{Li}(\text{tcnq})$,⁸ $[\text{Cu}_2\text{L}^2][\text{ClO}_4]_2$,¹⁹ $[\text{Cu}_2\text{L}^1][\text{tcnq}]_2$ ¹⁸ and $[\text{Cu}_2(\text{bipy})_2(\text{OH})_2][\text{tcnq}]_2$ ²⁰ as previously described.

Synthesis and characterisation of $[\text{Cu}_2\text{L}^2][\text{tcnq}]_3$

Using the Schlenk technique, a solution of $\text{Li}(\text{tcnq})$ (42.2 mg, 2×10^{-4} mol) in acetonitrile–methanol (1 : 1, 20 cm^3) was transferred under an argon atmosphere to acetonitrile (50 cm^3) containing $[\text{Cu}_2\text{L}^2][\text{ClO}_4]_2$ (83.6 mg, 10^{-4} mol) and tcnq (20.4 mg, 10^{-4} mol) dissolved at 50 °C. A dark green microcrystalline

powder formed after a few days at $-20\text{ }^{\circ}\text{C}$ and was filtered off, washed with cold acetonitrile and dried under vacuum (Found: C, 56.9; H, 2.8; Cu, 9.45; N, 17.6. Calc. for $\text{C}_{60}\text{H}_{32}\text{Cu}_2\text{F}_6\text{N}_{16}\text{O}_2$: C, 57.65; H, 2.6; Cu, 10.15; N, 17.95%). The infrared spectrum was recorded on a Perkin-Elmer 883 spectrophotometer and the UV/VIS spectrum on a Varian 2300 spectrophotometer. Samples were obtained by grinding 0.5 mg of material in 100 mg KBr and studied as pressed pellets.

Electrocrystallisation experiments

Starting compounds were purified as follows: $[\text{Cu}_2\text{L}^2][\text{ClO}_4]_2$ was recrystallised three times from water, tcnq three times from acetonitrile, NBu_4BF_4 once from water, and acetonitrile was dried first by distillation over P_2O_5 , then by column chromatography with alumina activated overnight at $400\text{ }^{\circ}\text{C}$. Typical crystallisation experiments were carried out at a platinum-wire cathode by constant-current electrolysis of tcnq (10 mg) in a solution of acetonitrile (40 cm^3) containing $[\text{Cu}_2\text{L}^2][\text{ClO}_4]_2$ (100 mg) and NBu_4BF_4 (500 mg). The cell was kept at $-30\text{ }^{\circ}\text{C}$, the compound being unexpectedly soluble at room temperature, contrary to most tcnq⁻ salts. The current was 10 μA , and the reaction was stopped after 50% of the electric current required for the tcnq reduction had been supplied.

Crystallography

Crystal data and data collection parameters. $\text{C}_{59}\text{H}_{32}\text{BrCu}_2\text{F}_3\text{N}_{16}\text{O}_2$, $M=1261$, triclinic, space group $P\bar{1}$ (no. 2), $a=8.541(6)$, $b=10.354(5)$, $c=15.730(8)$ \AA , $\alpha=85.87(4)$, $\beta=75.09(5)$, $\gamma=66.35(5)^\circ$, $U=1230.4(1.4)$ \AA^3 (by least-squares refinement on diffractometer angles from 18 centred reflections, $20 < 2\theta < 49^\circ$), $T=140\text{ K}$, graphite-monochromated Mo-K α radiation ($\lambda=0.71073$ \AA), $Z=1$, $D_c=1.702\text{ Mg m}^{-3}$, $F(000)=634$, black prism with dimensions $0.20 \times 0.17 \times 0.11$ mm, $\mu(\text{Mo-K}\alpha)=1.74\text{ mm}^{-1}$, empirical absorption correction based on DIFABS,²¹ minimum, maximum absorption corrections 0.85–1.20; Enraf-Nonius CAD4 diffractometer with low-temperature attachment, ω - 2θ scans, data collection range $2 < 2\theta < 56^\circ$, $+h, \pm k, \pm l$, three standard reflections showed no significant variation in intensity; reflections measured 6298, 5903 unique ($R_{\text{int}}=0.027$), 2369 with $I > 3\sigma(I)$ used in subsequent calculations.

Structure solution and refinement. A first model obtained from direct methods (SIR 92)²² suggested a centrosymmetric arrangement of the dinuclear copper cation and that the tcnq moieties were situated around an inversion centre. However, subsequent Fourier-difference synthesis based on this model did not locate the CF_3 group expected from the predicted formula $[\text{Cu}_2\text{L}^2][\text{tcnq}]_3$, but rather a broad and intense peak which corresponded roughly to 17 electrons at about 1.9 \AA from the carbon and three weak peaks around it. Owing to the synthetic procedure used to make the macrocycle, the possibility of a mixture of CF_3 and Br groups was considered. First the corresponding CF_3 group and Br atom in the disordered positions were given equivalent isotropic thermal parameters, whereas their occupancies were allowed to vary with the constraint that the sum equals unity. Additional distance and angle restraints within the CF_3 group (mean C–F 1.35 \AA , F–C–F and C–C–F 109°) were used. This procedure led to an occupancy factor of 0.5. The structure was then refined anisotropically, with the exception of the C atom of CF_3 which was kept isotropic, by least-squares procedures on $F(\text{CRYSTALS})$.²³ Hydrogen atoms were introduced in idealised positions [$d(\text{CH})=0.96$ \AA] and their atomic coordinates recalculated after each cycle. They were given isotropic thermal parameters 20% higher than those of the carbon to which they are attached. Least-squares refinements were carried out by minimising the function $\sum w(|F_o| - |F_c|)^2$, where F_o and F_c are the observed and calculated structure factors. The weighting scheme used in the last

refinement cycles was $w = w' \{1 - [\Delta F/6\sigma(F_o)]^2\}^2$ where $w' = 1/\sum A_r T_r(x)$ with three coefficients A_r (6.35, -3.63 , 4.79) for the Chebyshev polynomial $A_r T_r(x)$ where x was $F_c/F_o(\text{maximum})$.²⁴ The model converged to $R=0.078$ and $R' = 0.067$ [$R = \sum(|F_o| - |F_c|)/\sum(|F_o|)$ and $R' = [\sum w(|F_o| - |F_c|)^2/\sum w(F_o)^2]^{1/2}$] for 393 parameters, goodness of fit = 1.09, root mean square shift/standard deviation less than 0.7 and no real features in final difference maps ($\Delta\rho_{\text{min}}, \Delta\rho_{\text{max}} = -1.69, 0.83\text{ e \AA}^{-3}$).

Atomic coordinates, thermal parameters, and bond lengths and angles have been deposited at the Cambridge Crystallographic Data Centre (CCDC). See Instructions for Authors, *J. Chem. Soc., Dalton Trans.*, 1997, Issue 1. Any request to the CCDC for this material should quote the full literature citation and the reference number 186/426.

Magnetic measurements and conductivity

The magnetic susceptibility of $[\text{Cu}_2\text{L}^2][\text{tcnq}]_3$ (8 mg) was recorded as a function of the temperature, using a Faraday-type magnetometer equipped with a helium continuous-flow cryostat. A value of $-121 \times 10^{-6}\text{ cm}^3\text{ mol}^{-1}$ was used as the diamagnetic correction for tcnq,²⁵ and we estimated a value of -268×10^{-6} for $[\text{Cu}_2\text{L}^2]^{2+}$ from Pascal's constants.²⁶ X-Band powder EPR spectra were recorded on a Bruker ER 200 E spectrometer. Conductivities were measured at room temperature on pressed pellet samples.

Results and Discussion

Synthesis and stoichiometry

Modification of the crystallisation conditions can change the structure and stoichiometry even for tcnq complexes with the same cation.^{27,28} Since $[\text{Cu}_2\text{L}^1][\text{tcnq}]_2$ was easily obtained from $[\text{Cu}_2\text{L}^1][\text{ClO}_4]_2$ and $\text{Li}(\text{tcnq})$,¹⁸ we expected not only $[\text{Cu}_2\text{L}^2][\text{tcnq}]_3$ but $[\text{Cu}_2\text{L}^2][\text{tcnq}]_2$ as well. However all attempts to synthesize $[\text{Cu}_2\text{L}^2][\text{tcnq}]_2$ from $[\text{Cu}_2\text{L}^2][\text{ClO}_4]_2$ and $\text{Li}(\text{tcnq})$ without tcnq⁰ were unsuccessful. On the other hand, stoichiometry imposed by geometrical data had been previously observed for a molecular conductor.²⁹ The reason for this unexpected stoichiometry seems not to be related to our experimental technique, but to the size of the CF_3 -containing species which is bigger than that of the CH_3 -containing ones. As a consequence, the resulting increase in volume would be compensated by the introduction of one extra tcnq in the structure which arises from stacking of trimers.

Structure of $[\text{Cu}_2\text{L}^3][\text{tcnq}]_3$

Before discussing the crystallographic data, it has to be clearly stated that no single crystals of $[\text{Cu}_2\text{L}^2][\text{tcnq}]_3$ were obtained despite many attempts. For reasons that remain unclear, crystals suitable for structural determination were obtained only from a sample containing a small amount of $[\text{Cu}_2\text{L}^3][\text{ClO}_4]_2$. The presence of this by-product is readily understood by considering the synthesis of the macrocycle which implies a trifluoromethylation of 4-bromophenol. We have experienced that a small impurity of bromine remains in several samples of the macrocycle, which would have normally been discarded, but the difficulties encountered in its synthesis together with repeated unsuccessful crystallisations encouraged us to use any samples available. The few crystals obtained did not allow further physical measurements, but the magnetic and conductivity behaviour can be qualitatively understood from the structural data.

The bond lengths are summarised in Table 1 and refer to the atom-labelling scheme given in Fig. 1. The structure may be described as made of segregated stacks of $[\text{Cu}_2\text{L}^3]^{2+}$ and tcnq trimers and at first seems to be very closely related to $[\text{Cu}_2\text{L}^1][\text{tcnq}]_2$,¹⁸ which comprises two pseudo-segregated stacks of copper dimer units and dimerised tcnq, with some interaction through a weak Cu–NC bond. A more careful examination

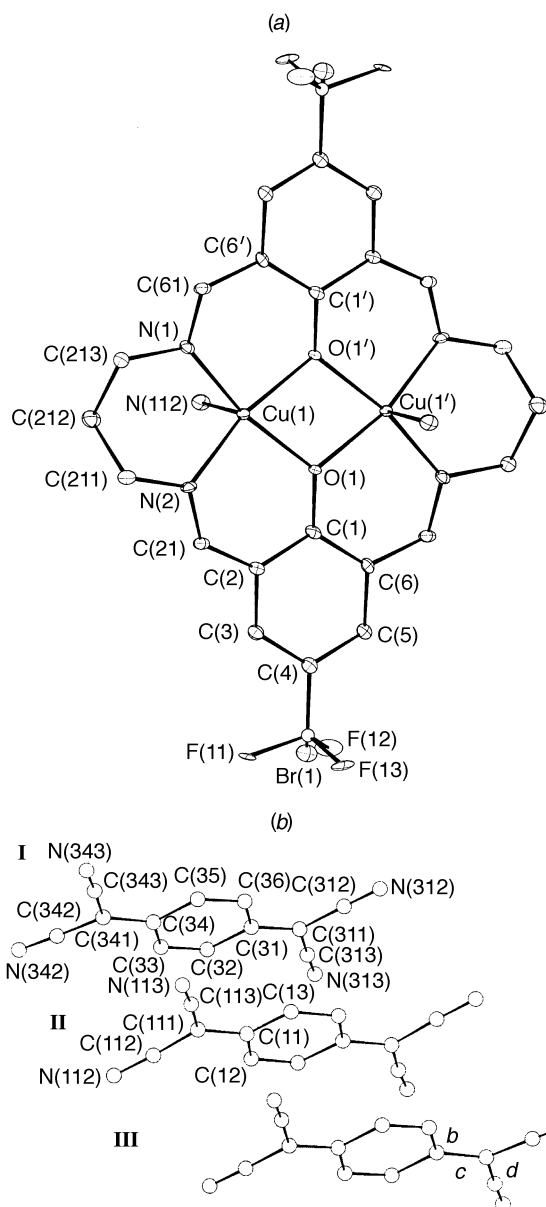

Fig. 1 Atom labelling scheme for $[\text{Cu}_2\text{L}^3][\text{tcnq}]_3$: (a) $[\text{Cu}_2\text{L}^3]^{2+}$, (b) $[\text{tcnq}]_3^{2-}$

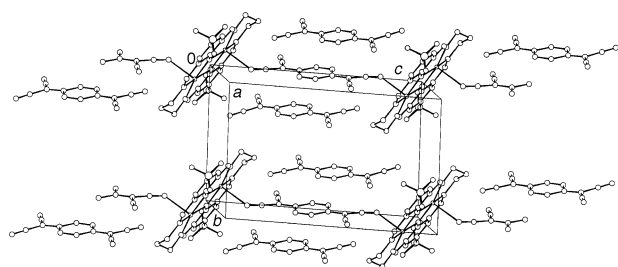

Fig. 2 Refined structure of $[\text{Cu}_2\text{L}^3][\text{tcnq}]_3$ showing the Cu-tcnq linkage that builds up the one-dimensional character

indicates that the extent of distortion is such that the present structure is best described as an alternated stack, with a Cu-tcnq linkage that builds up the one-dimensional character. A CAMERON³⁰ view of the structure is shown in Fig. 2. In a previous paper¹⁹ we reported that the structure of $[\text{Cu}_2\text{L}^2]^{2+}$ is surprisingly different from that of the related $[\text{Cu}_2\text{L}^1]^{2+}$ cation,³¹ as the molecular skeleton is far from being planar in the former. Despite the symmetry lowering by L^3 , a centre of inversion is present between the copper atoms in $[\text{Cu}_2\text{L}^3][\text{tcnq}]_3$.

Table 1 Principal interatomic distances (Å) and angles (°) for $[\text{Cu}_2\text{L}^3][\text{tcnq}]_3$ with estimated standard deviations in parentheses

$\text{Cu}(1) \cdots \text{Cu}(1')$	3.121(2)	$\text{Cu}(1)-\text{O}(1')$	1.969(5)
$\text{Cu}(1)-\text{O}(1)$	1.991(6)	$\text{Cu}(1)-\text{N}(2)$	1.959(7)
$\text{Cu}(1)-\text{N}(1)$	1.977(7)	$\text{Cu}(1)-\text{N}(112)$	2.434(7)
$\text{C}(11)-\text{C}(12)$	1.42(1)	$\text{N}(112)-\text{C}(112)$	1.16(1)
$\text{C}(11)-\text{C}(13)$	1.41(1)	$\text{N}(113)-\text{C}(113)$	1.14(1)
$\text{C}(11)-\text{C}(111)$	1.43(1)	$\text{C}(111)-\text{C}(112)$	1.40(1)
$\text{C}(12)-\text{C}(13)$	1.37(1)	$\text{C}(111)-\text{C}(113)$	1.43(1)
$\text{C}(31)-\text{C}(32)$	1.43(1)	$\text{C}(311)-\text{C}(312)$	1.43(1)
$\text{C}(31)-\text{C}(36)$	1.45(1)	$\text{C}(311)-\text{C}(313)$	1.41(1)
$\text{C}(31)-\text{C}(311)$	1.40(1)	$\text{C}(341)-\text{C}(342)$	1.43(1)
$\text{C}(32)-\text{C}(33)$	1.34(1)	$\text{C}(341)-\text{C}(343)$	1.44(1)
$\text{C}(33)-\text{C}(34)$	1.43(1)	$\text{N}(312)-\text{C}(312)$	1.15(1)
$\text{C}(34)-\text{C}(35)$	1.44(1)	$\text{N}(313)-\text{C}(313)$	1.14(1)
$\text{C}(34)-\text{C}(341)$	1.40(1)	$\text{N}(342)-\text{C}(342)$	1.16(1)
$\text{C}(35)-\text{C}(36)$	1.35(1)	$\text{N}(343)-\text{C}(343)$	1.14(1)
$\text{O}(1)-\text{Cu}(1)-\text{O}(1)$	76.0(2)	$\text{O}(1')-\text{Cu}(1)-\text{N}(112)$	95.9(3)
$\text{O}(1)-\text{Cu}(1)-\text{N}(1)$	167.4(2)	$\text{N}(1)-\text{Cu}(1)-\text{N}(2)$	98.1(3)
$\text{O}(1')-\text{Cu}(1)-\text{N}(1)$	93.4(3)	$\text{N}(1)-\text{Cu}(1)-\text{N}(112)$	91.8(3)
$\text{O}(1)-\text{Cu}(1)-\text{N}(2)$	91.7(3)	$\text{N}(2)-\text{Cu}(1)-\text{N}(112)$	91.6(3)
$\text{O}(1')-\text{Cu}(1)-\text{N}(2)$	166.1(3)	$\text{Cu}(1)-\text{O}(1)-\text{Cu}(1')$	104.0(2)
$\text{O}(1)-\text{Cu}(1)-\text{N}(112)$	95.9(2)		

The two copper atoms are bound to the four N and two O atoms of the macrocyclic ligand. The Cu_2O_2 system which results from the double oxygen bridge has unequal Cu-O bond lengths of 1.991(6) and 1.969(5) Å *versus* 1.977(3) and 1.965(3) Å in $[\text{Cu}_2\text{L}^1][\text{tcnq}]_2$. In addition, the Cu-O-Cu angle is equal to 104.0° in the present compound *versus* 104.2° in the methylated derivative. The elevation of the copper atom above the N_2O_2 basal mean plane toward the apex is 0.124 Å *versus* 0.153 Å for $[\text{Cu}_2\text{L}^1][\text{tcnq}]_2$. The copper co-ordination is completed by a weak bond at 2.434(7) Å between each copper and the N atom of a tcnq unit as observed for $[\text{Cu}_2\text{L}^1][\text{tcnq}]_2$ [2.378(5) Å]. The free apical position enforced by the square-planar ligand might offer a pathway for charge transfer in both materials.

The tcnq stack is shown in Fig. 2. It clearly indicates that the overlap between trimers is very modest. There are three different tcnq units, one being co-ordinated to two copper complexes through weak Cu-N bonds and surrounded by two others free of any interaction with copper.

Electronic structure of $[\text{Cu}_2\text{L}^3][\text{tcnq}]_3$

A trimerisation is characteristic of a Peierls distortion of a uniform stack in which $2n$ excess electrons are shared by $3n$ molecules.^{32,33} Although the redox potential $[\text{Cu}_2\text{L}^3]^{2+}-[\text{Cu}_2\text{L}^3]^+$ has not been determined, the data available for $\text{tcnq}^0-\text{tcnq}^-$ (0.37 V *vs.* normal hydrogen electrode, NHE),³⁴ *versus* those of $[\text{Cu}_2\text{L}^1]^{2+}-[\text{Cu}_2\text{L}^1]^+$ (-0.53 V *vs.* NHE)¹⁹ and $[\text{Cu}_2\text{L}^2]^{2+}-[\text{Cu}_2\text{L}^2]^+$ (-0.39 V *vs.* NHE)¹⁹ strongly indicate that the metal centres cannot be reduced from Cu^{II} to Cu^{I} . Therefore the charge distribution between cationic and anionic species is certainly $[\text{Cu}^{\text{II}}\text{L}^3]^{2+}(\text{tcnq})_3^{2-}$. This compound possesses two 'open-shell' sub-units (Cu^{II} and tcnq^-) that might result in paramagnetic properties. The magnetic properties have recently been investigated for Robson-type copper(II) dimers, in which each metal is weakly bonded to a ligand.³⁵ In any case, the copper atoms are strongly antiferromagnetically coupled, the magnitude of the interaction being larger as the displacement of the metal from the N_2O_2 mean plane decreases, since the overlap through the bridge, and hence the exchange pathway, is enhanced. This observation suggests a singlet-triplet energy difference for the $[\text{Cu}_2\text{L}^3]^{2+}$ fragments higher than the 835 cm^{-1} recorded for $[\text{Cu}_2\text{L}^1][\text{tcnq}]_2$.

The tcnq trimers bearing two unpaired electrons are an additional paramagnetic source for $[\text{Cu}^{\text{II}}\text{L}^3]^{2+}(\text{tcnq})_3^{2-}$. The point of interest is to determine whether the tcnq units are equally charged or not. The synthesis of several compounds exhibiting

Table 2 Differences in bond lengths for tcnq*

tcnq	(b - c)	(c - d)	(b - c) - (c - d)
I	+0.037	-0.027	+0.064
II	-0.015	+0.015	+0.000
III	+0.037	-0.027	+0.064

* See Fig. 1.

stacking of trimers which share two charges (+ or -) has been achieved and their electronic structures discussed in detail.^{30,36-39} The rule seems to be that in all $M^{2+}(\text{tcnq})_3^{2-}$ systems the tcnq units are not equivalent, therefore even if electrons may in some cases not be strictly localised on a single tcnq, an important asymmetry in the charge distribution is always observed. A refined crystal structure may give the ultimate answer to this question, according to the criteria of Flandrois and Chasseau,⁴⁰ based on the bond lengths (b, c, d) of tcnq (see Fig. 1). These authors have pointed out that the amount of charge borne by tcnq groups may be evaluated through the differences $b - c$ and $c - d$, the tendency being that a charge -1 can be assigned as the lengths become equal, while tcnq^0 exhibits $(b - c) - (c - d) = 0.131 \text{ \AA}$. The averaged values are given in Table 2.

The fact that tcnq II exhibits small bond-length differences, while equivalent I and III are significantly different, suggests that the electronic structure of the trimer might be $(\text{tcnq}^{0.5-})-(\text{tcnq}^-)(\text{tcnq}^{0.5-})$. This is consistent with the intuition that the tcnq moieties bonded to copper atoms are those bearing most of the negative charge. However, great care must be taken in this assignment, owing to the problems raised by the pseudo-centrosymmetry of the structure. An interplanar spacing of 3.13 Å between the tcnq units can be calculated. This value indicates a strong π interaction within the trimers and may be compared to the distance of 3.45 Å in non-interacting tcnq^0 ,⁴¹ 3.17 Å in ttf-tcnq [ttf = 2-(1,3-dithiol-2-ylidene)-1,3-dithiole (tetrathiafulvalene)],⁴² and 3.15 Å in $[\text{Cu}_2\text{L}^1][\text{tcnq}]_2$.¹⁸ Magnetic coupling between interacting tcnq^- units has frequently been observed to be very strongly antiferromagnetic, due to the strong π interaction.^{7,12a,43} It is therefore what is expected here in addition to a very modest conductivity.

Additional theoretical considerations can provide more evidence for the electron localisation in $[(\text{tcnq})_3]^{2-}$ through a simple Hückel approach. Assuming symmetric and isolated trimers, the secular determinant can be written as in equation (1)

$$\begin{vmatrix} \alpha - E & \beta & 0 \\ \beta & \alpha - E & \beta \\ 0 & \beta & \alpha - E \end{vmatrix} = 0 \quad (1)$$

(where $\alpha = \langle \psi_i | H | \psi_i \rangle$, $\beta = \langle \psi_i | H | \psi_{i+1} \rangle$ and E is the energy) which readily gives the solution shown in Fig. 3. If one fills the bonding level by two electrons, it is clear that the electron localisation will be $2 \times (0.5)^2 = 0.5$ on tcnq I and III, and $2 \times (0.707)^2 = 1$ on tcnq II. This qualitative assignment substantially agrees with that from the crystal data available.

Electronic structure of $[\text{Cu}_2\text{L}^2][\text{tcnq}]_3$

Spectroscopic properties. The IR and UV/VIS properties of tcnq salts can provide evidence that indicates whether the tcnq units are equally charged or not. In Table 3 several IR modes of tcnq in $[\text{Cu}_2\text{L}^2][\text{tcnq}]_3$, $[\text{Cu}_2\text{L}^1][\text{tcnq}]_2$ and $[\text{Cu}_2(\text{bipy})_2(\text{OH})_2][\text{tcnq}]_2$ are compared with those of Li^+tcnq^- and tcnq^0 as standards. These modes shift largely depending on the charge of tcnq^{9a,36b,45,46} but are rather similar for Li^+tcnq^- and $[\text{Cu}_2\text{L}^1][\text{tcnq}]_2$ in which tcnq^- only is present. It is clear from Table 3 that $[\text{Cu}_2\text{L}^2][\text{tcnq}]_3$ contains two kinds of tcnq molecules, which may be roughly assumed to be tcnq^0 and tcnq^- with an important charge localisation. It makes a crucial differ-

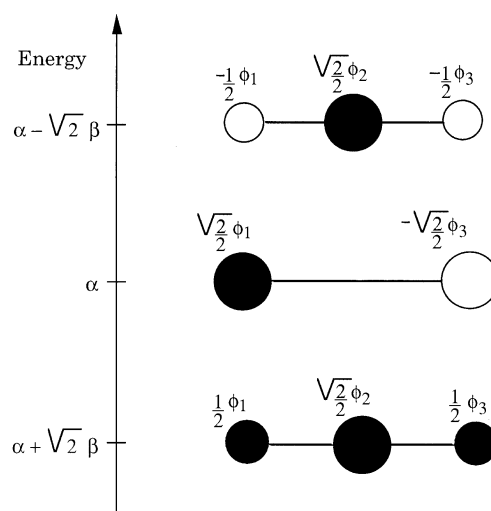
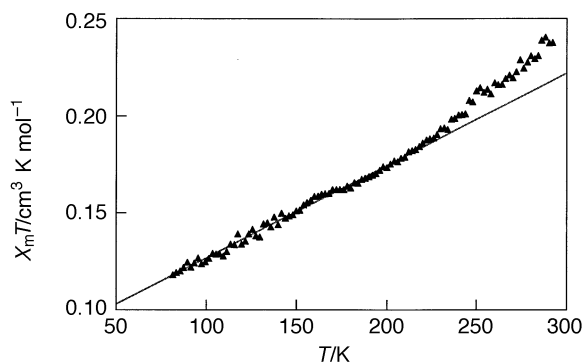
**Fig. 3** Energy levels and orbital descriptions from a simple Hückel calculation for symmetric trimers assuming a single ϕ_i orbital per site**Fig. 4** Plot of experimental $\chi_m T$ vs. T for $[\text{Cu}_2\text{L}^2][\text{tcnq}]_3$. The straight line is the fit provided by equation (2) (see text)

ence *versus* $[\text{Cu}_2(\text{bipy})_2(\text{OH})_2][\text{tcnq}]_2$ in which both tcnq^- and a little tcnq^0 should be present with an important electron delocalisation which averages the absorption signal. The data extracted from the electronic spectral data in Table 3 are consistent with the infrared data. The broad band at 1130 nm for $[\text{Cu}_2\text{L}^2][\text{tcnq}]_3$ could be tentatively attributed to a $\text{tcnq}^- - \text{tcnq}^- \rightarrow \text{tcnq}^0 \text{tcnq}^{2-}$ transition as observed by Torrance *et al.*⁴⁷ and others^{12,36a,48} for several tcnq^- salts in the range 850–1200 nm. On the other hand, this broad band is absent for $[\text{Cu}_2\text{L}^1][\text{tcnq}]_2$ and we suggest that it may be a $\text{tcnq}^- - \text{tcnq}^0 \rightarrow \text{tcnq}^0 \text{tcnq}^-$ transition. A similar band observed at 3175 nm for $[\text{Cu}_2(\text{bipy})_2(\text{OH})_2][\text{tcnq}]_2$ can likely be attributed to the same $\text{tcnq}^- - \text{tcnq}^0 \rightarrow \text{tcnq}^0 \text{tcnq}^-$ transition, the electrons being much more delocalised in this compound, due to the smaller energy difference. In conclusion from the spectroscopic data it is clear that two kinds of tcnq are present in $[\text{Cu}_2\text{L}^2][\text{tcnq}]_3$. The charges are expected to be strongly localised and therefore a very low conductivity should be observed.

Magnetic and conductivity properties. The magnetic properties of $[\text{Cu}_2\text{L}^2][\text{tcnq}]_3$ are shown in Fig. 4 in the form of the plot of $\chi_m T$ versus T (χ_m being the molar magnetic susceptibility and T the temperature). It is clear that at low temperature $\chi_m T$ varies linearly *versus* T according to the relation (2). In this

$$\chi_m T = \alpha + \gamma T \quad (2)$$

equation α is associated with localised unpaired electrons (some free tcnq^- was identified by EPR spectroscopy as an impurity)

Table 3 Spectroscopic data for tcnq in $[\text{Cu}_2\text{L}^2][\text{tcnq}]_3$ and related compounds as KBr pellets

(a) Infrared (cm^{-1})					
Mode*	$[\text{Cu}_2(\text{bipy})_2(\text{OH})_2][\text{tcnq}]_2$	$[\text{Cu}_2\text{L}^1][\text{tcnq}]_2$	$[\text{Cu}_2\text{L}^2][\text{tcnq}]_3$	Li^+tcnq^-	tcnq ⁰
Ag ²	2194	2193	2195 2227	2181	2223
Ag ³	1509	1504	1505 1541	1505	1541
Bu ⁵⁰	824	818	823 858	828	863

(b) Electronic ($\lambda_{\text{max}}/\text{nm}$)			
$[\text{Cu}_2(\text{bipy})_2(\text{OH})_2][\text{tcnq}]_2$	$[\text{Cu}_2\text{L}^1][\text{tcnq}]_2$	$[\text{Cu}_2\text{L}^2][\text{tcnq}]_3$	
3175		1130	
602	610	610	
		430	
356	358	356	
298	272	285	

* Numbered according to ref. 44.

Table 4 Magnetic data extracted from EPR spectra recorded on powder samples at room temperature and at 4 K for $[\text{Cu}_2\text{L}^2][\text{tcnq}]_3$ and related compounds compared with those of $\text{Li}(\text{tcnq})$

Compound	Room temperature <i>g</i> (bandwidth/G)	4 K <i>g</i> (bandwidth/G)
$[\text{Cu}_2\text{L}^2][\text{tcnq}]_3$	2.008 (80)	<i>a</i>
$[\text{Cu}_2\text{L}^1][\text{tcnq}]_2^b$		
$[\text{Cu}_2(\text{bipy})_2(\text{OH})_2][\text{tcnq}]_2$	2.082 (30)	2.101 (180)
Li^+tcnq^-	2.002 (2)	<i>a</i>

^a No signal observed. ^b No signal at any temperature.

and γ is ascribed to the temperature-independent Pauli paramagnetism; α was found to be $0.0795 \text{ cm}^3 \text{ K mol}^{-1}$ and γ $4.75 \times 10^{-4} \text{ cm}^3 \text{ mol}^{-1}$. This type of temperature dependence has been observed for some tcnq salts of copper chelates.^{9a,20,49} On the other hand, it is very closely related to that of $[\text{Cu}_2\text{L}^1][\text{tcnq}]_2$ previously reported,¹⁸ consistent with the fact that two tcnq⁻ radicals are expected to be very antiferromagnetically coupled, while tcnq⁰ is an innocent unit as regards the magnetic properties. As the temperature is increased a triplet state starts to be thermally populated and the $\chi_m T$ product becomes significantly larger than expected.

It is not possible to determine the origin of the magnetism [copper(II) or tcnq⁻] at high temperature from the magnetic susceptibility measurements only, and additional information on the nature of the spin carriers may be deduced from the EPR spectra. The data recorded for $[\text{Cu}_2\text{L}^2][\text{tcnq}]_3$ are compared with those of related compounds in Table 4. It can be seen that the behaviour of the fluorinated material is intermediate between that of the weakly interacting copper–tcnq system and the strongly interacting one. Since $[\text{Cu}_2\text{L}^2][\text{ClO}_4]_2$ and $[\text{Cu}_2\text{L}^1][\text{tcnq}]_2$ are EPR silent, the weak signal recorded at room temperature must be associated with the tcnq stacks, and therefore should be assigned a *g* value of 2.002. The actual value recorded *g* 2.008 indicates that some contribution from the metal (*g* = 2.088)⁵⁰ is involved. As an averaged value of 2.045 would be associated with $[\text{Cu}^{\text{I}}\text{Cu}^{\text{II}}\text{L}^2][\text{tcnq}^-][\text{tcnq}^0]_2$, the 2.008 value clearly indicates that the reduction of the metal by tcnq⁻ is far from being achieved even if interactions can take place through the weak Cu–tcnq bonding. It suggests that increasing the interaction may restore some magnetism to the composite material, which is no longer EPR silent.

The conductivities recorded on a crystal of $[\text{Cu}_2\text{L}^2][\text{tcnq}]_3$ and a powder sample of $[\text{Cu}_2\text{L}^3][\text{tcnq}]_3$ are given in Table 5, and compared with the available data for the related tcnq salts. The results indicate that although the fluorinated materials con-

Table 5 Conductivity ($\text{ohm}^{-1} \text{ cm}^{-1}$) for $[\text{Cu}_2\text{L}^2][\text{tcnq}]_3$, $[\text{Cu}_2\text{L}^3][\text{tcnq}]_3$, and related compounds

Compound	Crystal	Powder
$[\text{Cu}_2\text{L}^3][\text{tcnq}]_3$	10^{-5}	
$[\text{Cu}_2\text{L}^2][\text{tcnq}]_3$		1.5×10^{-4}
$[\text{Cu}_2\text{L}^1][\text{tcnq}]_2$	5×10^{-5a}	10^{-3a}
$[\text{Cu}_2(\text{bipy})_2(\text{OH})_2][\text{tcnq}]_2$	<i>b</i>	6×10^{-3c}

^a Data from ref. 18. ^b No crystal available. ^c Data from ref. 20.

tain mixed-valence tcnq stacks, the conductivity is lower than that of $[\text{Cu}_2\text{L}^1][\text{tcnq}]_2$. However, it is consistent with the fact that the stack of tcnq trimers might be more distorted than that of the tcnq dimers. The poor conductivity is also supported by the presence of two kinds of tcnq, which involve electron localisation as discussed above. The complex $[\text{Cu}_2(\text{bipy})_2(\text{OH})_2][\text{tcnq}]_2$ in which no isolated tcnq⁰ were detected exhibits a better conductivity, in agreement with the low-lying $\text{tcnq}^-\text{tcnq}^0 \rightarrow \text{tcnq}^0\text{tcnq}^-$ electronic transition. These conductivities and magnetic measurements are consistent, as a lower conductivity resulting in a more magnetic compound is observed for tcnq salts.⁵¹

It is of great interest that better conductivities are obtained for powder samples than for single crystals in these family of copper–tcnq materials. The true origin of the conductivity has not clearly been established for these compounds,^{18,20} and the question arises as to whether or not the tcnq stacks are the only conduction path. A small amount of trimerisation is known to affect dramatically the conductivity of low-dimensional conductors.³⁹ As $[\text{Cu}_2\text{L}^2][\text{tcnq}]_3$ shows no overlap between the (tcnq)₃ units, a conductivity as large as $1.5 \times 10^{-4} \text{ } \Omega^{-1} \text{ cm}^{-1}$ is rather surprising, and suggests that some additional path might be found in the material. If so, it would most likely take place through the weak Cu–tcnq bond. It is clear, however, that further theoretical investigations (*e.g.* band-structure calculations) would be required to resolve this question.

Conclusion

In the search for new materials the interest in molecular chemistry is probably due to its ability to affect deeply the properties of the solid state by introducing small modifications at the molecular level. Low-dimensional conductors may be the best example to illustrate the ability of molecular engineering. In this study we have investigated the influence of a CF₃ substitution on a dimeric copper(II) salt of tcnq. The first and unexpected result was a new stoichiometry imposed by the size of the cationic species compared with the related CH₃-containing compound. Two trifluoromethylated compounds were obtained, $[\text{Cu}_2\text{L}^2][\text{tcnq}]_3$ and $[\text{Cu}_2\text{L}^3][\text{tcnq}]_3$, the properties of which were very similar. The addition of an extra tcnq⁰ resulted in few of the properties expected for a mixed-valence tcnq stack, the structure showing rather isolated tcnq trimers bearing two very strongly coupled electrons. On the other hand, a better adjustment in the redox potential of the constitutive units was achieved, and even if it didn't allow a partial charge transfer from tcnq⁻ to Cu^{II}, it restored a very modest magnetism, which mainly arises from the tcnq⁻.

It would be worthwhile to perform further studies based on a Robson-type binucleating ligand substituted with a better electron-acceptor group, such as NO₂.

Acknowledgements

The authors thank Dr. Patrick Batail for collecting the X-ray data.

References

- 1 J. S. Miller, A. J. Epstein and W. M. Reiff, *Chem. Rev.*, 1988, **88**, 201; J. S. Miller and A. J. Epstein, *Adv. Chem. Ser.*, 1990, **226**, 419; W. E. Broderick, J. A. Thompson, E. P. Day and B. M. Hoffman, *Science*, 1990, **249**, 401; D. O'Hare, M. D. Ward and J. S. Miller, *Chem. Mater.*, 1990, **2**, 758.
- 2 A. F. Garito and A. J. Heeger, *Acc. Chem. Res.*, 1974, **7**, 232.
- 3 J. B. Torrance, *Acc. Chem. Res.*, 1979, **12**, 80.
- 4 H. Endres, in *Extended Linear Chain Compounds*, ed. J. S. Miller, Plenum, New York, 1983, vol. 3, p. 263.
- 5 W. Kaim and M. Moscherosch, *Coord. Chem. Rev.*, 1994, **129**, 157.
- 6 See, for example, W. Broderick, D. M. Eichhorn, X. Liu, P. J. Toscano, S. M. Owens and B. M. Hoffman, *J. Am. Chem. Soc.*, 1995, **117**, 3641 and refs. therein.
- 7 P. J. Kunkeler, P. J. van Koningsbruggen, J. P. Cornelissen, A. N. van der Horst, A. M. van der Kraan, A. L. Spek, J. G. Haasnoot and J. Reedijk, *J. Am. Chem. Soc.*, 1996, **118**, 2190.
- 8 L. R. Melby, R. I. Harder, W. R. Hertler, W. Mahler, R. E. Benson and W. E. Mochel, *J. Am. Chem. Soc.*, 1962, **84**, 3374.
- 9 (a) M. Inoue and M. B. Inoue, *Inorg. Chem.*, 1986, **25**, 37; (b) M. B. Inoue, M. Inoue, Q. Fernando and K. W. Nebesny, *J. Phys. Chem.*, 1987, **91**, 527.
- 10 A. Bencini, S. Midollini and C. Zanchini, *Inorg. Chem.*, 1989, **28**, 1963; A. Bencini and C. Zanchini, *Inorg. Chem.*, 1991, **30**, 4245.
- 11 S. K. Hoffmann, P. J. Corvan, P. Singh, C. N. Sethulekshmi, R. M. Metzger and W. E. Hatfield, *J. Am. Chem. Soc.*, 1983, **105**, 4608.
- 12 M. Schwartz and W. E. Hatfield, (a) *Inorg. Chem.*, 1987, **26**, 2823; (b) *NATO ASI Ser. B*, 1987, **168**, 345.
- 13 W. J. Wang and S. S. Wang, *Synth. Met.*, 1991, **42**, 1729; W. J. Wang and J. Y. Jeng, *Synth. Met.*, 1988, **27**, B205.
- 14 H. Wang, Y. Chen, J. Li and L. Bai, *Inorg. Chim. Acta*, 1988, **148**, 261.
- 15 M. Qian, D. Zhu, M. Li and Z. Zhang, *Sci. Sin., Ser. B*, 1986, **29**, 136.
- 16 D. G. Humphrey, G. D. Fallon and K. S. Murray, *J. Chem. Soc., Chem. Commun.*, 1988, 1356.
- 17 R. C. Wheland, *J. Am. Chem. Soc.*, 1976, **98**, 3926.
- 18 P. Lacroix, O. Kahn, A. Gleizes, L. Valade and P. Cassoux, *New J. Chem.*, 1984, **8**, 643.
- 19 P. Lacroix, O. Kahn, F. Theobald, J. Leroy and C. Wakselman, *Inorg. Chim. Acta*, 1988, **142**, 129.
- 20 P. Lacroix, O. Kahn, L. Valade, P. Cassoux and L. K. Thompson, *Synth. Met.*, 1990, **39**, 81.
- 21 DIFABS, N. G. Walker and D. Stuart, *Acta Crystallogr., Sect. A*, 1983, **39**, 158.
- 22 A. Altomare, G. Cascarano, G. Giacovazzo, A. Guagliardi, M. C. Burla, G. Polidori and M. Camalli, SIR 92, a program for automatic solution of crystal structures by direct methods, *J. Appl. Crystallogr.*, 1994, **27**, 435.
- 23 D. J. Watkin, C. K. Prout, J. R. Carruthers and P. W. Betteridge, CRYSTALS, Issue 10, Chemical Crystallography Laboratory, University of Oxford, 1996.
- 24 E. Prince, *Mathematical Techniques in Crystallography*, Springer, Berlin, 1982.
- 25 J. C. Scott, A. F. Garito and A. J. Heeger, *Phys. Rev. B: Solid State*, 1974, **10**, 3131.
- 26 A. Earnshaw, *Introduction to magnetochemistry*, Academic Press, London, 1968.
- 27 L. Firlej, P. Bernier, F. Rachdi, M. Ribet, J. Pecherz and U. Enkelmann, *Synth. Met.*, 1991, **42**, 1659; A. Tracz, J. K. Jeszka, M. Kryszewski, J. Ulanski, G. Boiteux, L. Firlej and A. Graja, *Synth. Met.*, 1988, **24**, 107.
- 28 M. D. Ward and D. C. Johnson, *Inorg. Chem.*, 1987, **26**, 4213.
- 29 A. Penicaud, P. Batail, K. Bechgaard and J. Sala Pala, *Synth. Met.*, 1988, **22**, 201.
- 30 D. J. Watkin, C. K. Prout and L. J. Pearce, CAMERON, Chemical Crystallography Laboratory, University of Oxford, 1996.
- 31 B. F. Hoskins, N. J. McLeod and H. A. Schaap, *Aust. J. Chem.*, 1976, **29**, 515.
- 32 W. P. Su and J. R. Schrieffer, *Phys. Rev. Lett.*, 1981, **46**, 738.
- 33 J. T. Gammel and J. A. Krumhansl, *Phys. Rev. B*, 1983, **27**, 1659.
- 34 M. L. Kaplan, R. C. Haddon, F. B. Bramwell, F. Wudl, J. H. Marshall, D. O. Cowan and S. Gronowitz, *J. Phys. Chem.*, 1980, **84**, 427.
- 35 L. K. Thompson, S. K. Mandal, S. S. Tandon, J. N. Bridson and M. K. Park, *Inorg. Chem.*, 1996, **35**, 3117; S. K. Mandal, L. K. Thompson, M. J. Newlands, E. J. Gabe and K. Nag, *Inorg. Chem.*, 1990, **29**, 1324; S. K. Mandal, L. K. Thompson, M. J. Newlands and E. J. Gabe, *Inorg. Chem.*, 1989, **28**, 3707.
- 36 (a) A. D. Bandrauk, K. Ishii, K. D. Truong, M. Aubin and A. W. Hanson, *J. Phys. Chem.*, 1985, **89**, 1478; (b) A. D. Bandrauk, K. D. Truong, C. Carlone and S. Jandl, *J. Phys. Chem.*, 1985, **89**, 434.
- 37 H. Kobayashi, T. Danno and Y. Saito, *Acta Crystallogr., Sect. B*, 1973, **29**, 2693.
- 38 C. J. Fritchie, jun. and P. Arthur, *Acta Crystallogr.*, 1966, **21**, 139.
- 39 J. P. Legros, M. Bousseau, L. Valade and P. Cassoux, *Mol. Cryst., Liq. Cryst.*, 1983, **100**, 181.
- 40 S. Flandrois and D. Chasseau, *Acta Crystallogr., Sect. B*, 1977, **33**, 2744.
- 41 R. E. Long, R. A. Sparks and K. N. Trueblood, *Acta Crystallogr.*, 1965, **18**, 932.
- 42 T. J. Kristenmacher, T. E. Phillips and D. O. Cowan, *Acta Crystallogr., Sect. B*, 1974, **30**, 763.
- 43 J. S. Miller, J. C. Calabrese, R. L. Harlow, D. A. Dixon, J. H. Zhang, W. M. Reiff, S. Chittipèddi, M. A. Selover and A. J. Epstein, *J. Am. Chem. Soc.*, 1990, **112**, 5496.
- 44 R. Bozio, I. Zanon, A. Girlando and C. Pecile, *J. Chem. Soc., Faraday Trans. 2*, 1978, **74**, 235.
- 45 W. J. Wang, *Synth. Met.*, 1991, **42**, 1723.
- 46 J. G. Robles-Martinez, A. Salmeron-Valverde, E. Alonso and C. Soriano, *Inorg. Chim. Acta*, 1991, **179**, 149.
- 47 J. B. Torrance, B. A. Scott and F. B. Kaufman, *Solid State Commun.*, 1975, **17**, 1369.
- 48 L. J. Yu, *Synth. Met.*, 1991, 1745; 1751.
- 49 M. B. Inoue and M. Inoue, *Chem. Phys. Lett.*, 1981, **80**, 585; T. Seto, M. Inoue, M. B. Inoue and D. Nakamura, *Bull. Chem. Soc. Jpn.*, 1983, **56**, 1903.
- 50 R. C. Long and D. N. Hendrickson, *J. Am. Chem. Soc.*, 1983, **105**, 1513.
- 51 R. G. Kepler, *J. Chem. Phys.*, 1963, **39**, 3528.

Received 21st October 1996; Paper 6/07166J